

# Instruction Manual

impression<sup>&</sup>  
X1



from software version: 1.0



— since 1994 —

support@glp.de  
www.glp.de

Notes:

---

---

---

---

---

---

---

---

---

---

---

---

---

---

---

---

---

---

---

---

---

---

---

---

---

## Table of contents

<b>1</b>	<b>Description of Device</b> .....	<b>4</b>
<b>2</b>	<b>Safety Instructions</b> .....	<b>5</b>
<b>3</b>	<b>Mounting</b> .....	<b>7</b>
	3.1.1 <i>Operating on the Floor (Upright)</i> .....	8
	3.1.2 <i>Mounting in hanging position</i> .....	8
	3.1.3 <i>Mounting in sideways Position</i> .....	9
	3.2 <i>Securing the Fixture</i> .....	10
	3.3 <i>Connections</i> .....	10
	3.3.1 <i>Power Supply</i> .....	10
	3.3.2 <i>NEUTRIK® powerCON</i> .....	10
	3.3.3 <i>DMX</i> .....	11
<b>4</b>	<b>The Menu Field</b> .....	<b>12</b>
<b>5</b>	<b>DMX Channel Selection (DMX Protocol)</b> .....	<b>14</b>
	5.1 <i>Normal Mode (18 DMX channels)</i> .....	14
	5.2 <i>Compressed Mode (14 DMX channels)</i> .....	16
<b>6</b>	<b>Maintaining and Cleaning</b> .....	<b>18</b>
	6.1 <i>Safety regulations</i> .....	18
	6.2 <i>Maintenance and Interval (rule-of-thumb)</i> .....	18
<b>7</b>	<b>Technical Specifications</b> .....	<b>19</b>
<b>8</b>	<b>Dimensions</b> .....	<b>20</b>
<b>9</b>	<b>Index</b> .....	<b>21</b>

# 1 Description of Device

- 1. Moving head (actively and passively cooled)
- 2. Arm of device
- 3. LCD-Display/Menu (data entry)
- 4. Base with various connectors, air in/outlets and mounting system
- 5. Fuse holder (on the bottom)

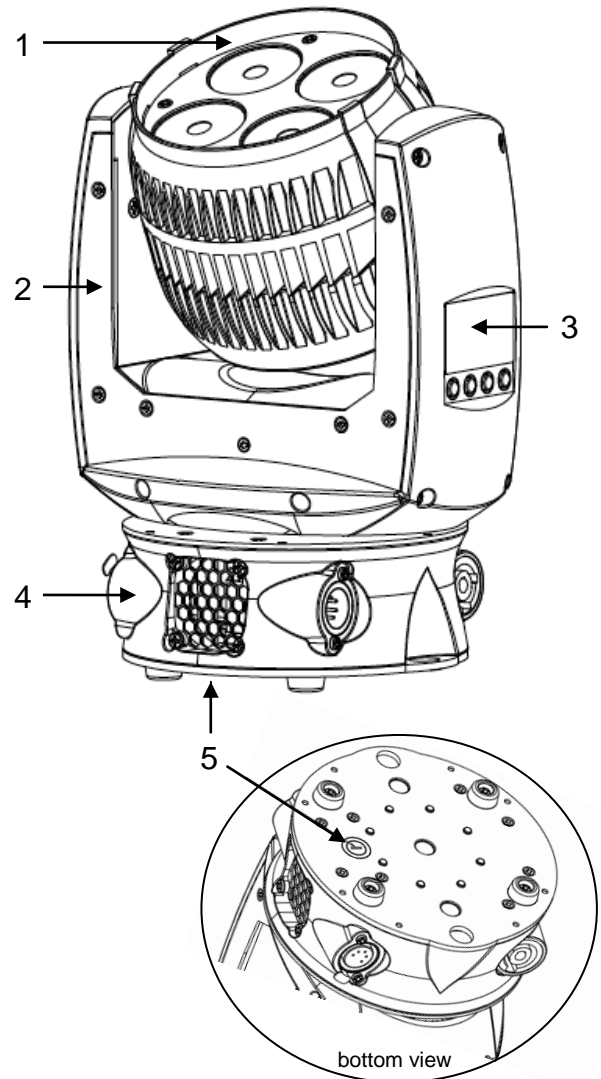

## Base sideview:

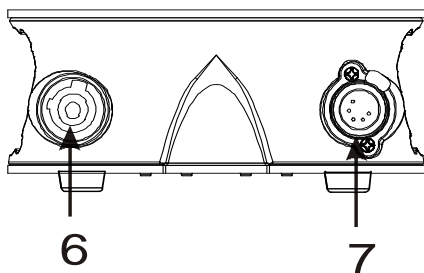

6. Mains Out (powerCON grey)

7. DMX- Output (5-pin)

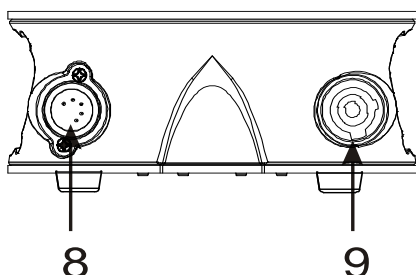

8. DMX- Input (5-pin)

9. Mains In (powerCON blue)

## 2 Safety Instructions



The **IMPRESSION X1** is a High-Tech Product. To guarantee a smooth operation, it is necessary to respect the following rules. The manufacturer of this device will not take responsibility for damages through any disregard of the information provided in this manual. Warranty claims also will be voided in the case that the fixture housing is opened.



**Never look directly into the beam of light or into one of the LEDs.** **Attention:** LED Class 2M can cause injuries of your eyes even without optical instruments in front of them or within a distance of less than 0.5m and short exposure time.  
Hence: Avoid direct radiation into your eyes!



**WARNING:**

**Never** let optical parts come in contact with alcohol, solvents or similar cleaners.

1. Before powering on the fixture, make sure that the fixtures fans and air inlets are clean and not blocked.
2. Ensure that the fixture head can rotate unhindered throughout its complete range of pan and tilt movement. A safety distance of at least 0.5 m must be maintained between the fixture and any easily inflammable material (e.g. decoration material).
3. **Attention!** Don't touch the fixture during the operation. This can cause injuries and/or damages.
4. **The fixture doesn't contain any user serviceable parts. Opening the fixture will void all warranties.**
5. It is necessary to wait at least 15 minutes after disconnecting the mains power before handling the fixture.. Pay attention to possible hot parts of the fixture.

6. To ensure safe operation, follow also the Installation guide described in the chapter below. Operating the **IMPRESSION X1** without suitable safety aids like Safety cables or clamps/hooks can increase the risk of an accident and must be avoided.
7. Repair, maintenance, and installation work shall be done by qualified or GLP certified staff only. You need to pay attention to the common rules of technology that are not explicitly mentioned in this manual.
8. Use only original GLP spare parts. Any structural modification of the system will terminate all warranty claims.
9. Please keep this instruction manual for future reference.
10. Should you have any questions about the operation of your fixture then please contact your local GLP office, or their authorized distributor, a list of which can be found at [www.glp.de](http://www.glp.de).

### 3 Mounting

The **IMPRESSION X1** is fully operational whether it hangs or is mounted to the wall. It can also be operated while standing on the floor. Keep a safety distance of min. 0.5 m towards any easily inflammable materials (decoration etc.).

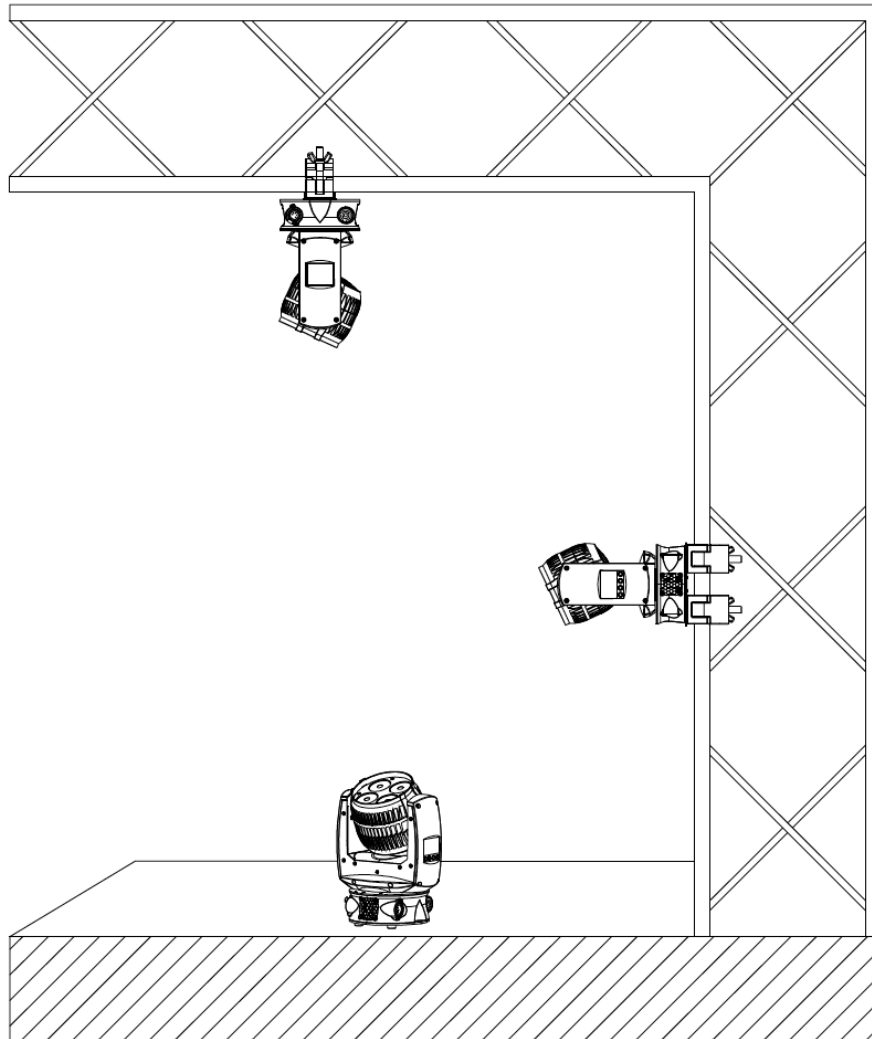

**Pay attention to the regulations of: BGV C1 (former VBG 70), DIN VDE 0711-217 and BGI 810-3.**

**The installation shall be done by qualified staff only.**

For the various mounting positions of the **IMPRESSION X1** (standing on the floor, sideways or hanging) different connectors are available. Through this a safe and firm installation is assured. You'll find dedicated M10 threads on the bottom side of the fixture which should be used. In addition the top of the base is marked with a **FRONT** arrow allowing consistent orientation during installation.

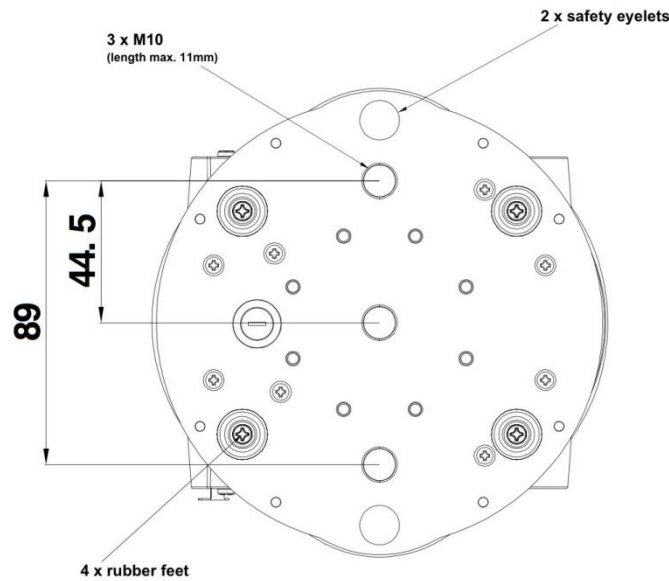

Fixture from below

### 3.1.1 Operating on the Floor (Upright)

The **IMPRESSION X1** is fitted with 4x solid rubber feet which allows a stable standing of the fixture. An additional securing is usually not required. Please pay attention to an even and gripping surface.

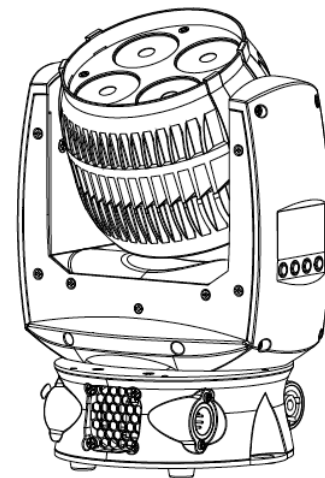

### 3.1.2 Mounting in hanging position

To operate the **IMPRESSION X1** in a hanging position please use a half-coupler (clamp). This can be mounted directly to the bottom side of the fixture. It should be attached centrally with a M10 mm thread bolt (**max. length 11mm**).

**Attention: Never use a longer bolt as this may damage the interior of the fixture.**



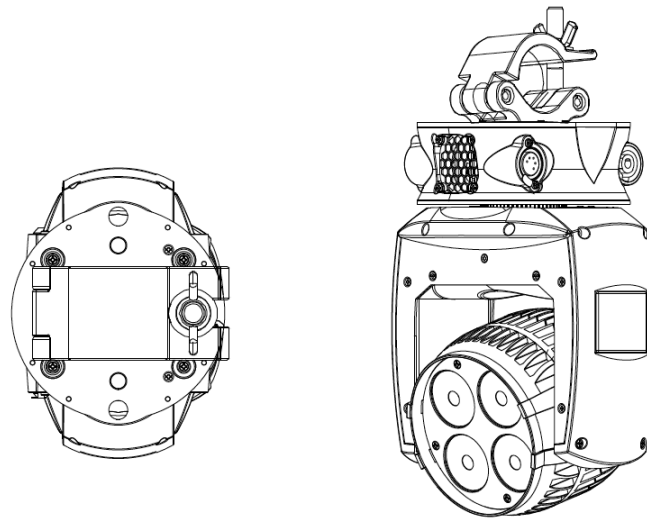

### 3.1.3 Mounting in sideways Position

To operate the **IMPRESSION X1** in a sideways position please use two half-couplers (clamps) attached to the bottom side of the base. They should be attached with M10 mm thread bolts (max. length 11mm).

This technique is necessary to cope with the torque which accrues in this mounting position. Never use the "Mounting in hanging position" technique described above to fasten the fixture in the sideways position. A safe and sound installation cannot be assured in this way. In addition this can damage the fixture base.

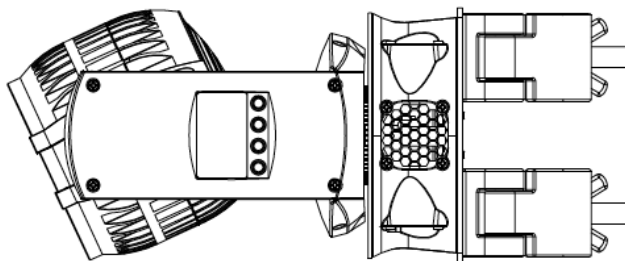

**Attention: Always use two (2) half-couplers for sideway mounting.**

### 3.2 Securing the Fixture

Regardless of the mounting method of the **IMPRESSION X1** you'll have to use a stipulated safety wire. Attach the safety wire through one of the two holes provided on the base of the fixture and connect it to the primary support structure. Pay attention to a safe and proper fastening. The safety cable must comply with BGI 810-3 (EN 60598-2-17 Section 17.6.6) and be capable of bearing a static suspended load that is ten times the weight of the fixture and all installed accessories.

### 3.3 Connections

#### 3.3.1 Power Supply

~100-240 Volt AC, 50-60 Hz, powerCON AC connector

Connected load 85 VA (W) <=> T2A (micro-fuse 5x20mm)

Please also see the printing on the case!

**Disconnect from the mains supply for changing the fuse and use only the above described micro-fuse type.**

#### 3.3.2 NEUTRIK® powerCON

The IMPRESSION X1 is fitted with NEUTRIK® powerCON locking 3 conductor AC connectors.

The grey connector must be used to draw AC mains power from the fixtures` throughput sockets and the blue connectors must be used to supply power at the fixtures` power input socket.

The total number of fixtures in one interconnected chain depends on your local AC mains voltage but you must never connect more than a total load of 20A to stay within the limits of the connector. The total load includes all connected fixtures including the first one in the chain.

**Note: The maximum allowed total - load is 20A including the first fixture in one interconnected daisy chain.**

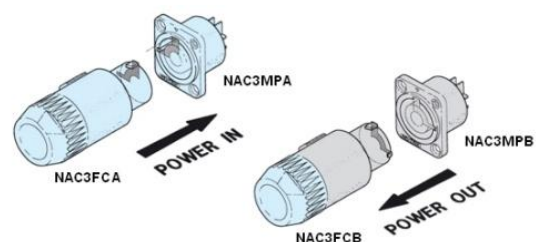

Please note that there are two different generations of NEUTRIK® powerCON connectors (Type NAC3FCA). Due to different mechanical dimensions, only the newer version of these two can be used for **impression X1** fixtures.

You can identify the correct version by the imprint on the side and the NEUTRIK® Logo on the lock latch.

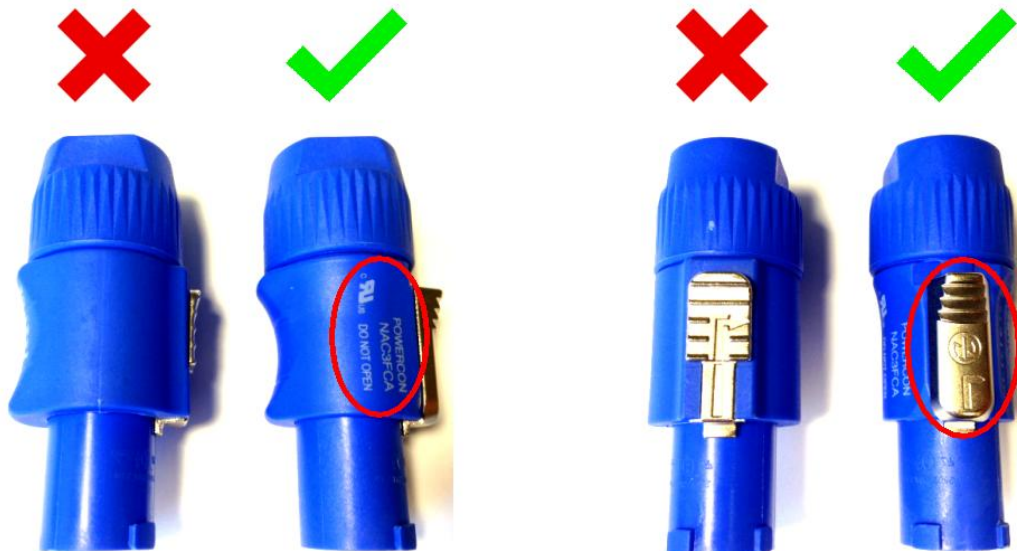

### 3.3.3 DMX

USITT DMX-512 Standard input/output in 5-pin connectors.

Pin 1 = [Ground] / Pin 2 = [-] / Pin 3 = [+] / Pin 4 & 5 N.C.

The DMX- Addressing starts at the DMX- Address [001].

## 4 The Menu Field

You'll find the control board on the side part of the arm. It allows you to make all necessary adjustments of the **IMPRESSION X1**. With the **Mode**-key you get into the main menu. Afterwards you can navigate through the menu with the **Up/Down**-keys. Push the **Enter**-key to get in the next menu level or to confirm your settings. Make them and set functions **ON/OFF** with the **Up/Down**-keys. Confirm and save it with the **Enter**-key (the display shows **OK**). Push the **Mode**-key to cancel the entry and go back to the main menu.

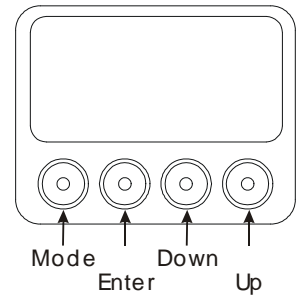

To lock or unlock the keys of the menu field press **Mode+Enter+Up** simultaneously.

### ← MODE - ENTER →

Level1	Level 2	Level 3	Level 4	Remark	
DMX Start Address 001				Set the DMX start address	
Special	Manual DMX			Manual control of all fixture functions	
		Pan		Manual control for Pan (X-movement)	
		Pattern		Manual control for Pattern channel / bank	
		Speed Movements		Manual control for Pan/Tilt movements	
		Pan/Tilt Movements		Manual control for Pan/Tilt movements	
		Special		Manual control for Special functions	
		White Temperature		Manual control for Color temperature	
		Dimmer		Manual control for Dimmer	
		Shutter		Manual control for Shutter	
		White		Manual control for White	
		Blue		Manual control for blue	
		Green		Manual control for green	
		Red		Manual control for red	
		Color Wheel		Manual control for the color wheel	
	Tilt		Manual control for Tilt (Y-movement)		
	Adjust				
		Key code xxxx			Use the code for entering the calibration menu (for authorized persons only)
		Display Contrast			Adjustment for the Display contrast
		PWM - Frequ. Adj.			Changes PMW frequency
		Max Zoom adjust			Calibration of Zoom-offset
		Pan Offset			Calibration for Pan-offset
		Tilt Offset			Calibration for Tilt-offset
		LED 100mA/1A adjust			Adjust dimming of the LEDs
		LED adjust			
				White adjust red	Adjust intensity for red channel
			White adjust blue	Adjust intensity for blue channel	
			White adjust green	Adjust intensity for green channel	
Clear EEPROM			Erase EEPROM memory		

← DOWN - UP →

← DOWN - UP →

	<b>BL-Diagnose</b>	Diagnose of Boot-loader
	<b>Diagnose</b>	Diagnose fixture functions
<b>Temperature Head</b>		Read out head temperature
<b>Default full feature</b>		Reset all settings to factory defaults
<b>Display Black out</b>		Auto switch-off display illumination after 10 seconds
<b>DMX hold</b>		Holds last DMX signal in case of signal loss
<b>DMX Image</b>		
	<b>Set image if DMX off</b>	Activates a stored scene if DMX is off
	<b>Save image in memory</b>	Stores the scene currently sent to the unit
<b>Set dimming mode</b>		Linear Dimming / Extr. soft dimming / Soft dimming
<b>DMX input Monitor</b>		Indicates the presently received DMX signal per DMX channel
	<b>Pan</b>	Instantaneous value for Pan
	<b>Pattern</b>	Instantaneous value for Pattern channel / bank
	<b>Speed Movements</b>	Speed adjustment for Pan/Tilt movements → see item below
	<b>Pan/Tilt Movements</b>	Instantaneous value for Pan/Tilt movements
	<b>Special</b>	Instantaneous value for Special
	<b>White Temperature</b>	Adjustment of the color temperature for WHITE
	<b>Dimmer</b>	Instantaneous value for Dimmer
	<b>Shutter</b>	Instantaneous value for Shutter
	<b>White</b>	Instantaneous value for White
	<b>Blue</b>	Instantaneous value for Blue
	<b>Green</b>	Instantaneous value for Green
	<b>Red</b>	Instantaneous value for Red
	<b>Color Wheel</b>	Instantaneous value for Color Mixing unit
	<b>Tilt</b>	Instantaneous value for Tilt
<b>Self test program</b>		Initiates a self-test program
<b>Live time</b>		On-time of fixture
<b>Set DMX Mode</b>		Select the desired DMX Mode
	<b>Compressed Mode</b>	Fixture works in "Compressed" mode → see also section 0 unterhalb
	<b>Normal Mode</b>	Fixture works in "Normal" mode → see also section 0 unterhalb
	<b>High-Res. Mode</b>	Fixture works in "High Resolution" mode → see also section 0 unterhalb
<b>Position feedback</b>		Switch automatic position feedback ON/OFF
<b>Reverse Pan</b>		Invert Pan movements: ON/OFF
<b>Reverse Tilt</b>		Invert Tilt movements: ON/OFF
<b>Reset</b>		RESET and new calibration for all functions

## 5 DMX Channel Selection (DMX Protocol)

### 5.1 Normal Mode (18 DMX channels)

Channel	Function	Time and Value	DMX
<b>1 Pan - High</b>	Pan coarse	0° - 660°	0..255
<b>2 Pan - Low</b>	Pan fine		0..255
<b>3 Tilt - High</b>	Tilt coarse	0° - 300°	0..255
<b>4 Tilt - Low</b>	Tilt fine		0..255
<b>5 Color (fixed)</b>	Colors adjustable via RGB		0..7
	Color 01 - Red <sup>1)</sup>		8..15
	Color 02 - Amber <sup>1)</sup>		16..23
	Color 03 - Warm Yellow <sup>1)</sup>		24..31
	Color 04 - Yellow <sup>1)</sup>		32..39
	Color 05 - Green <sup>1)</sup>		40..47
	Color 06 - Turquoise <sup>1)</sup>		48..55
	Color 07 - Cyan <sup>1)</sup>		56..63
	Color 08 - Blue <sup>1)</sup>		64..71
	Color 09 - Lavender <sup>1)</sup>		72..79
	Color 10 - Malve <sup>1)</sup>		80..87
	Color 11 - Magenta <sup>1)</sup>		88..95
	Color 12 - Pink <sup>1)</sup>		96..103
	White – CTO	3200K	104..111
	White	5600K	112..119
	White – CTB	7200K	120..127
	Rainbow Effect Stop <sup>2)</sup>		128
	Rainbow Effect <sup>3)</sup>	slow - fast	129..223
	Random colors	slow - fast	224..255
<b>6 Red</b>	Color mixing system - Red	0 - 100%	0..255
<b>7 Green</b>	Color mixing system - Green	0 - 100%	0..255
<b>8 Blue</b>	Color mixing system - Blue	0 - 100%	0..255
<b>9 White</b>	Color mixing system - White	0 - 100%	0..255
<b>10 Shutter</b>	Shutter closed		0..15
	Shutter pulse random	slow – fast	16..47
	Fade on, snap off (random patterns)	slow – fast	48..79
	Snap on, fade off (random patterns)	slow – fast	80..111
	Fade on, fade off (random patterns)	slow – fast	112..143
	Strobe random	5s - 0.1s	144..199
	Strobe effect slow - fast	1 Hz - 10 Hz	200..239
	Shutter open		240..255

<b>11 Intensity</b>	Dimmer	0 - 100%	0..255	
<b>12 CTO</b>	No CTO	<i>Applicable</i>	0..7	
	Continuously 2,500k – 10,000k	<i>for ALL colors</i>	8..255	
<b>13 Special</b>	<b>RESET</b>	<b>&gt; 1 sec</b>	<b>250..255</b>	
<b>14 Movement</b>  <b>Macros</b>	No macros		0..0	
	<b>Movement</b>	<b>Speed</b>	<b>Phase</b>	<i>Use channel 15 to adjust</i>
	Pan	1	0°	01..01
	Pan	1	90°	02..03
	Pan	1	180°	04..05
	Pan	1	270°	06..07
	Pan	2	0°	08..09
	Pan	2	90°	10..11
	Pan	2	180°	12..13
	Pan	2	270°	14..15
	Pan	3	0°	16..17
	Pan	3	90°	18..19
	Pan	3	180°	20..21
	Pan	3	270°	22..23
	Pan	4	0°	24..25
	Pan	4	90°	26..27
	Pan	4	180°	28..29
	Pan	4	270°	30..31
	Tilt	size / phase see Pan		32..63
	Pan / Tilt	size / phase see Pan		64..95
	Pan / Tilt (inverse)	size / phase see Pan		96..127
Circle	size / phase see Pan		128..159	
Circle (inverse)	size / phase see Pan		160..191	
Lying eight	size / phase see Pan		192..223	
Random movement	size / phase see Pan		224..255	
<b>15 Pan / Tilt</b> <b>Speed</b>	Pan/Tilt movement speed from controller		0..1	
	Pan/Tilt, slow – fast <i>Use this channel for the speed of the macros on channel 14</i>		2..255	
<b>16 None</b>	reserved		-	
<b>17 Pan - rotation</b>	No rotation		0..5	
	Pan rotation CW	slow – fast	6..130	
	Pan rotation CCW	fast - slow	131..255	
<b>18 Tilt - rotation</b>	No rotation		0..5	
	Tilt rotation CW	slow – fast	6..130	
	Tilt rotation CCW	fast - slow	131..255	

## 5.2 Compressed Mode (14 DMX channels)

Channel	Function	Time and Value	DMX
<b>1 Pan - High</b>	Pan coarse	0° - 660°	0..255
<b>2 Pan - Low</b>	Pan fine		0..255
<b>3 Tilt - High</b>	Tilt coarse	0° - 300°	0..255
<b>4 Tilt - Low</b>	Tilt fine		0..255
<b>5 Color (fixed)</b>	Colors adjustable via RGB		0..7
	Color 01 - Red <sup>1)</sup>		8..15
	Color 02 - Amber <sup>1)</sup>		16..23
	Color 03 - Warm Yellow <sup>1)</sup>		24..31
	Color 04 - Yellow <sup>1)</sup>		32..39
	Color 05 - Green <sup>1)</sup>		40..47
	Color 06 - Turquoise <sup>1)</sup>		48..55
	Color 07 - Cyan <sup>1)</sup>		56..63
	Color 08 - Blue <sup>1)</sup>		64..71
	Color 09 - Lavender <sup>1)</sup>		72..79
	Color 10 - Malve <sup>1)</sup>		80..87
	Color 11 - Magenta <sup>1)</sup>		88..95
	Color 12 - Pink <sup>1)</sup>		96..103
	White – CTO	3200K	104..111
	White	5600K	112..119
	White – CTB	7200K	120..127
	Rainbow Effect Stop <sup>2)</sup>		128
	Rainbow Effect <sup>3)</sup>	slow - fast	129..223
	Random colors	slow - fast	224..255
<b>6 Red</b>	Color mixing system - Red	0 - 100%	0..255
<b>7 Green</b>	Color mixing system - Green	0 - 100%	0..255
<b>8 Blue</b>	Color mixing system - Blue	0 - 100%	0..255
<b>9 White</b>	Color mixing system - White	0 - 100%	0..255
<b>10 Shutter</b>	Shutter closed		0..15
	Shutter pulse random	slow – fast	16..47
	Fade on, snap off (random patterns)	slow – fast	48..79
	Snap on, fade off (random patterns)	slow – fast	80..111
	Fade on, fade off (random patterns)	slow – fast	112..143
	Strobe random	5s - 0.1s	144..199
	Strobe effect slow - fast	1 Hz - 10 Hz	200..239
	Shutter open		240..255
<b>11 Intensity</b>	Dimmer	0 - 100%	0..255



12 Special	RESET	> 1 sec	250..255
13 Pan rotation	No rotation		0..5
	Pan rotation CW	slow – fast	6..130
	Pan rotation CCW	fast - slow	131..255
14 Tilt - rotation	No rotation		0..5
	Tilt rotation CW	slow – fast	6..130
	Tilt rotation CCW	fast - slow	131..255

<sup>1)</sup> The predefined colors can be used as start-colors for the Rainbow effect. Please select first a desired start-color before you activate the rainbow effect. All **IMPRESSION X1** will then start from that color and will execute the rainbow effect synchronously. Different **IMPRESSION X1** can have different start-colors but will still execute the rainbow effect synchronously. If you choose a color different from the ones marked with <sup>1)</sup> in the tables above the rainbow start-color will be red.

<sup>2)</sup> Rainbow-effect Stop will pause this function. After resuming the rainbow-effect will be continued from the current color.

<sup>3)</sup> The Rainbow-effect will run synchronously only if started from one of the predefined colors (see also point <sup>1)</sup> before).

### Locking and unlocking the Control Panel

Please lock and unlock the control panel by pressing the menu keys **MODE & ENTER & UP** at the same time.

### Additional Display Indications

As a default you'll find the following additional information in the first row of the LCD display:

Vxx/xx/xx/xx/x (e.g. V1.16/10/16/NN/NS)

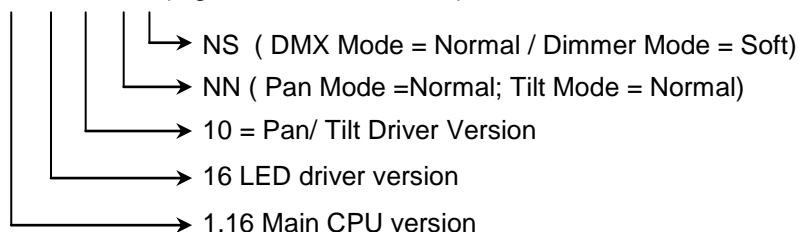

## 6 Maintaining and Cleaning

The **IMPRESSION X1** is a fixture of very low maintenance. It is only necessary to clean the air inlets and outlets as well as the optical LED lenses from time to time. For safe operation it is absolutely essential that the fixture is kept clean and that dust, dirt and smoke-fluid residues must not build up on, or within the fixture. Otherwise the fixture's light-output will be significantly reduced or damages can occur. Regular cleaning will not only ensure the maximum light-output, but will also allow the fixture to operate reliably throughout its life.

**A soft lint-free cloth moistened with any good glass cleaning fluid is recommended, under no circumstances should alcohol or solvents be used!**



**Attention:**

Under **no** circumstances should alcohol or solvents be used to clean the lenses!

### 6.1 Safety regulations

- **Pull out the mains power plug!**
- Wait min. 15 minutes after disconnecting power to allow the fixture to cool down.

### 6.2 Maintenance and Interval (rule-of-thumb)

The contamination of the fixture depends on the environment details. Hence no general guidelines can be given. The intervals given below are only suggestions from our experience.

Position	Interval	In this way
LED reflector and optical system	weekly	soft brush /lint-free cloth
Fan and air channel	monthly	vacuum cleaner, airbrush, etc.

**Attention:**

- **Never let optical parts come into contact with oil, fat, alcohol or similar solvents.**
- **Before running the fixture wait until all parts are dry.**
- **Never touch lenses with bare fingers.**

## 7 Technical Specifications

<b>Power supply</b>	
<b>Power consumption</b>	85 VA (Watt)
<b>Power Input</b>	Auto sensing 100-240 V AC, 50-60 Hz
<b>Power connectors</b>	NEUTRIK® powerCON Power-in: NAC3FCA / NAC3MPA (blue) Power-out: NAC3FCB / NAC3MPB (grey)
<b>Fuse protection</b>	Micro-fuse 5x20 mm, T2A
<b>Operational Parameters</b>	
<b>Max. Ambient Temperature</b>	5° - 45°C (integrated overheating switch) 40°-113°F
<b>Mounting Position</b>	Any (see relevant chapter)
<b>Lighting System - Additive Color mixing</b>	
<b>LED Type</b>	4 x Osram Ostar RGBW multi-chip
<b>Lifetime</b>	50,000 h
Wavelength optimized for maximum presentable color space	
<b>Optical System</b>	
Full RGBW / High efficient Collimator cluster Interchangeable lens carrier with 7° beam angle as standard option	
<b>Shutter / Dimmer (8/16 Bit)</b>	
Strobe- Effect with variable speed between 1-10 flashes per second, Random & Pulse-Effects Continuous Dimmer 0 - 100%	
<b>DMX Control</b>	
Standard USITT DMX-512, 5 pin XLR: [+]=Pin 3 / [-]=Pin 2 / [Ground]=Pin 1 / Pin 4 & 5 N.C. The DMX- Addressing starts at the DMX channel [001].	
<b>Pan / Tilt (8/16 Bit)</b>	
<b>Pan- movement</b>	<b>660° in min. 2 seconds (Position Feedback)</b>
<b>Pan - rotation</b>	<b>endless pan-rotation with adjustable speed</b>
<b>Tilt- movement</b>	<b>360° in min. 0.9 seconds (Position Feedback)</b>
<b>Tilt - rotation</b>	<b>endless tilt-rotation with adjustable speed</b>
<b>Weights and Measures</b>	
<b>Width</b>	<b>140 mm / 5.5''</b>
<b>Length</b>	<b>190 mm / 7.5''</b>
<b>Height (head vertical)</b>	<b>250 mm / 9.9''</b>
<b>Weight (net)</b>	<b>3.1 kg / 6.8 lbs</b>

## 8 Dimensions

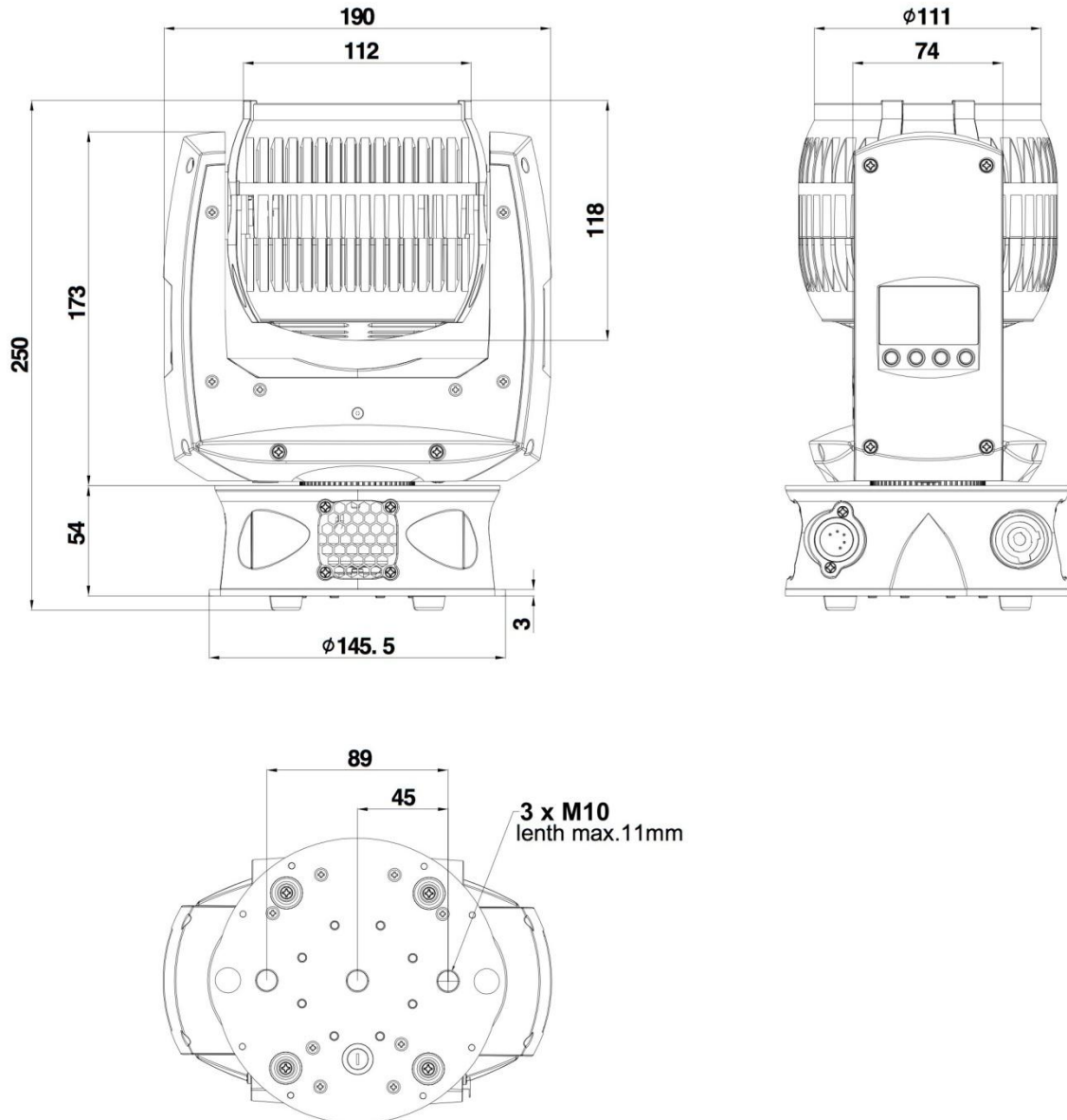

## 9 Index

<hr/>	
<b>B</b>	
BGV C1.....	7
<hr/>	
<b>C</b>	
Cleaning.....	17
<hr/>	
<b>D</b>	
Description of Device.....	4
Dimensions.....	19
DIN VDE 0711-217.....	7
<b>Display Indications</b> .....	16
<b>DMX</b> .....	11
<hr/>	
<b>E</b>	
e-mail.....	1
EN 60598-2-17.....	10
<b>Enter-key</b> .....	12
<hr/>	
<b>M</b>	
Maintenance.....	17
Menu Field.....	12
Micro-fuse.....	10
<b>Mode-key</b> .....	12
Mounting.....	7
Mounting in hanging Position.....	8
Mounting in sidewise Position.....	9
Mounting on the Floor.....	8
<hr/>	
<b>N</b>	
NEUTRIK® powerCON.....	10
Normal-Mode.....	14
<hr/>	
<b>O</b>	
<b>Optical parts</b> .....	17
<hr/>	
<b>P</b>	
Pan- Movement.....	18
<b>Power Supply</b> .....	10
<hr/>	
<b>S</b>	
Safety distance.....	7
Safety Instructions.....	5
<b>Secure the Device</b> .....	10
Software Version.....	1
<hr/>	
<b>T</b>	
Technical Specifications.....	18
Tilt- Movement.....	18
<hr/>	
<b>U</b>	
<b>Up/Down-keys</b> .....	12
<hr/>	
<b>V</b>	
VBG 70.....	7
<hr/>	
<b>W</b>	
Warranty claims.....	6
Weights and Measures.....	18

